



**Liftomatic Material Handling, Inc.**

700 Dartmouth Lane  
Buffalo Grove, IL 60089

Phone 847 325-2930  
Fax 847 325-2959  
Toll Free 800 837-6540

# LIFTOMATIC OWNERS MANUAL

## LIFTOMATIC “PARROT-BEAK®” DRUM HANDLING EQUIPMENT

### PORTABLE UNIT SERIES THE “ERGO-MATIC®” COUNTER BALANCE DRUM TRANSPORT FOR SINGLE DRUM MOVEMENT

***WARNING: Do not install, operate or service this product unless you have read and understand the safety practices, warnings, and operation and service instructions contained in this manual. Failure to follow these guidelines may result in less than efficient drum handling routines. Please consult Liftomatic if you require additional information or if you have questions. (PH: 800.837.6540 or FAX: 847.325.2959 or email: [info@liftomatic.com](mailto:info@liftomatic.com)). Thank you very much for your business.***



## Liftomatic Material Handling, Inc.

700 Dartmouth Lane  
Buffalo Grove, IL 60089

Phone 847 325-2930  
Fax 847 325-2959  
Toll Free 800 837-6540

### OPERATIONS OVERVIEW ERGO-MATIC® DRUM TRANSPORTER MODEL ERGO650-CB-ML

The Ergo-Matic product line was developed in 1994 for customers having applications to lift, lower, transport and position drums without the use of a forklift truck. Certain applications, including laboratories, pilot plants, research facilities and testing sites have physically restricted areas that are not conducive to the long load centers of forklifts, stackers and attachments. Thus, the Ergo-Matic was conceived, designed and brought to market.

Today, several thousand Ergo-Matic units are at work around the world. Perfect for operations requiring male and female operators to manipulate drums in tight spaces, the line has been expanded to include over 20 models with various features and options to suit nearly any applications.

#### **ERGO650-CB-ML OPERATING INSTRUCTIONS:**

Your new Ergo-Matic unit arrives shrink wrapped and strapped to a pallet. To begin, remove the shrink-wrap, cut the banding and use a forklift or other lifting device to remove the unit from the pallet. With a pallet ramp, the unit can also be wheeled from the pallet manually. Follow the ensuing steps.

- 1) Check the unit to see that no visible damage has occurred in the shipping process. Inspect wheels, corners, the parrot-beak® clamping mechanism and all buttons, pedals, and fittings.
- 2) When the unit is removed from the pallet and all wrapping materials are discarded, you are ready to begin using the unit. Proceed by moving the unit in position so the parrot-beak clamp is lowered to a point where the jaw assembly is below the top rim of the drum to be engaged. This can be done by depressing the large pump (lift) pedal, or the small (lowering) pedals. If needed, the parrot-beak clamp can also be raised or lowered within the inner frame by changing the head/pin location (there are several hole locations to choose from). This may be required if attempting to handle a drum smaller or shorter than a standard 55-gallon drum. Pump the lifting pedal several times so the inner frame extends beyond the outer frame. From there you will see the various adjustment holes the beak can be located.
- 3) Push the unit so the parrot-beak clamp makes contact with the drum. Holding the unit against the drum (or setting the floor lock), depress the large pump pedal. The hydraulic jack will lift approximately one inch with each pump, thus raising the parrot-beak head assembly. Continue to pump several more times, and the clamp jaws will automatically engage (grab) the drum.
- 4) In the event that the drum is to be moved to a different area prior to placement, do not lift the drum more than six (6") inches from the floor during transport. **NOTE: \*\*NEVER MOVE THE ERGO UNIT WHILE DRUM IS LIFTED MORE THAN SIX INCHES OFF THE GROUND. DOING SO MAY CAUSE DAMAGE TO THE UNIT AND/OR INJURY TO EMPLOYEES. ALWAYS TRANSPORT THE DRUM WHEN ONLY A FEW INCHES OFF THE GROUND.**



## Liftomatic Material Handling, Inc.

700 Dartmouth Lane  
Buffalo Grove, IL 60089

Phone 847 325-2930  
Fax 847 325-2959  
Toll Free 800 837-6540

### **ERGO650-CB-ML OPERATION INSTRUCTIONS- CONT'D.**

- 1) When you are ready to position the drum for placement at the new location, position the unit head-on to the drum's destination and raise or lower accordingly until the drum clears the platform (pallet, scale, etc.) to be set down on. When the bottom of the drum is clear of the surface to be set on, push the unit forward until the drum bottom is fully over that surface. Lower the drum fully until the Parrot-Beak mechanism releases (upper and lower jaws of the Parrot-Beak must be disengaged or the drum will not completely release). This is accomplished by pushing forward on the small lowering pedal located on the black lift cylinder pump. When the drum is released, simply move the Ergo unit away from the drum and the procedure can repeat.
  
- 2) **IMPORTANT!!!** There are three (3) capacity adjustment settings on the lower chassis of the unit along the middle braces that allow the unit to "telescope". These adjustment holes have a bolt and nylock nut going through the frame and outer-most portion of the chassis leg. If the bolts on both sides were to be removed, the chassis could be separated into two pieces. The shortest adjustment (both pieces of the chassis pushed closest together) is a 500-pound capacity setting. The middle adjustment hole is a 650-pound capacity setting and is the standard setting. The outermost adjustment setting is for the 800-pound capacity upgrade. Please adjust the setting to the required capacity. This adjustment allows the user to shorten or lengthen the unit for workspace confinement and provides a range of operating capacities. *\*\*Liftomatic always ships the unit in the correct capacity setting agreed on your companies order.*  
**NOTE: IF ANY EMPLOYEE MODIFIES THE CHASSIS POSITION, TESTING THE UNIT FOR PROPER LIFTING CAPACITY IS NEEDED BEFORE PUTTING THE UNIT INTO SERVICE. NEVER USE THE ERGOMATIC ON DRUMS THAT ARE HEAVIER THAN THE RATED CAPACITY OF THE UNIT.**
  
- 3) Also be sure to verify the flooring surface drums will be transported on. Liftomatic recommends manual products should not be used on inclines greater than five (5) degrees. For steep inclines, contact Liftomatic for information on the Ergomatic Power Series equipment.
  
- 4) Keep hands and feet away from the parrot-beak clamping mechanism (and wheels) during product operation. Also, keep product operation to ONE person to eliminate lifting or lowering at inappropriate times.
  
- 5) Be certain that all components are securely in place before operating this Ergo-Matic unit. Regular inspections should be followed prior to any operator using the Ergo-Matic. See maintenance section.

## Liftomatic Material Handling, Inc.

700 Dartmouth Lane  
Buffalo Grove, IL 60089

Phone 847 325-2930  
Fax 847 325-2959  
Toll Free 800 837-6540

## II. MAINTENANCE INSTRUCTIONS- ERGO650-CB-ML

- 1) The Ergo650-CB-ML unit requires little in the way of routine maintenance. Three main components are to be considered. They are:
  - A) **Lifting Jack/Foot Pump.** The lifting mechanism is a manual “pump” depression system. This hydraulic pump also requires little attention. In fact it is a sealed component and should not be tampered with. One fitting connects the foot pump hose to the lifting jack at the front of the unit. Standard hydraulic oil (300-330 Viscosity @ 100 degrees F) is to be used (only if a refill is required). Refills are to be made into the foot pump assembly. Contact Liftomatic with any questions at 800-837-6540 or [www.liftomatic.com](http://www.liftomatic.com)
  - B) **Parrot-Beak clamping mechanism.** The Parrot-Beak mechanism is designed to handle a complete range of steel, fiber and plastic drums. The mechanism is automatic and mechanical and does not require adjustment. The components that make up the clamping mechanism are both machined and cast. All are heat-treated and critical components are surface hardened. The only maintenance required is an occasional application of light grade oil (WD-40 or similar) sprayed into the inner moving parts of the clamp assembly to keep it free of debris and to allow the workings of the upper and lower jaw to move freely. Inspect the clamp to be sure springs are in place and no parts or fasteners are broken or missing. Liftomatic recommends replacing the springs and links within the beak once a year (more often in high usage applications).
  - C) **Wheels.** The wheels on the Ergo650-CB-ML are full bearing wheels and are a polyurethane derivative which is intended to handle a variety of surfaces and still be non-marking. Inspect wheels for wear and inordinate tread wear as regular maintenance is performed. Wheels can be replaced by contacting the factory or your authorized Liftomatic distributor. All fasteners to wheels should be inspected regularly for wear.

Should you have operating, maintenance or service questions please contact Liftomatic by phone at 1-800-837-6540 or via the Internet at <http://www.liftomatic.com> or email us at [Sales@liftomatic.com](mailto:Sales@liftomatic.com) and let us help. We look forward to your contact and as always, we thank you for your business!



**Liftomatic Material Handling, Inc.**

700 Dartmouth Lane  
Buffalo Grove, IL 60089

Phone 847 325-2930  
Fax 847 325-2959  
Toll Free 800 837-6540

**PART LIST ERGO650-CB-ML  
#5077-CB/ML**

<b>No.</b>	<b>Part Number</b>	<b>Quantity</b>	<b>Description</b>
1	2218	1	Front Frame
2	16092	1	Clevis Pin, Upper
3	6387	1	Bushing
4	6063	2	Circular pin
5	6281	1	Hydraulic Cylinder
	6281-1		High Rise Hydraulic Cylinder
6	6377	1	Hose Fitting, Upper
7	6378	1	Breather
8	2225	1	Enclosure, ML
9	52016	6	Counter Weight
10	2216	1	Rear Frame
11	6376	1	Hose Fitting, Elbow
12	6282	1	Foot Pump
13	6273	4	Hex Bolt 1/2-13 x 1-3/4"
14	6094	4	Hex Nut 1/2-13
15	6174	2	Caster 5" x 2"
16	6092	8	Hex Nut 5/16-18
17	6303	8	Flat HD Screw 5/16-18
18	6079	8	Lock Washer 5/16
19	6094	2	Hex Nut 1/2-13
20	6301	2	Hex Bolt 1/2-13 x 3"
21	16059	1	Wheel Axle
22	6177	1	Front Wheel
23	6077	2	Flat Washer
24	6061	2	Cotter Pin 3/16 X 1-3/4"
25	8004-1	4	Tapered Roller
26	6015 & 6016	8	Round Shim
27	6003	4	Cotter Pin
28	6151	1	Belt
29	2193-CB-ML	1	Inner Frame
30	4066-E	1	Single Clamp Head
	4066-ES		Single Clamp Head Spark-Resistant
	4083		Double Head Clamp
	4083-SRJ		Double Head Clamp Spark-Resistant
31	6388	1	Clevis Pin, Lower
32	6009	1	Cotter Pin 1/8 x 1-1/2"
33	6377	1	Hose Fitting, Lower
34	6384-48	1	Hydraulic Hose

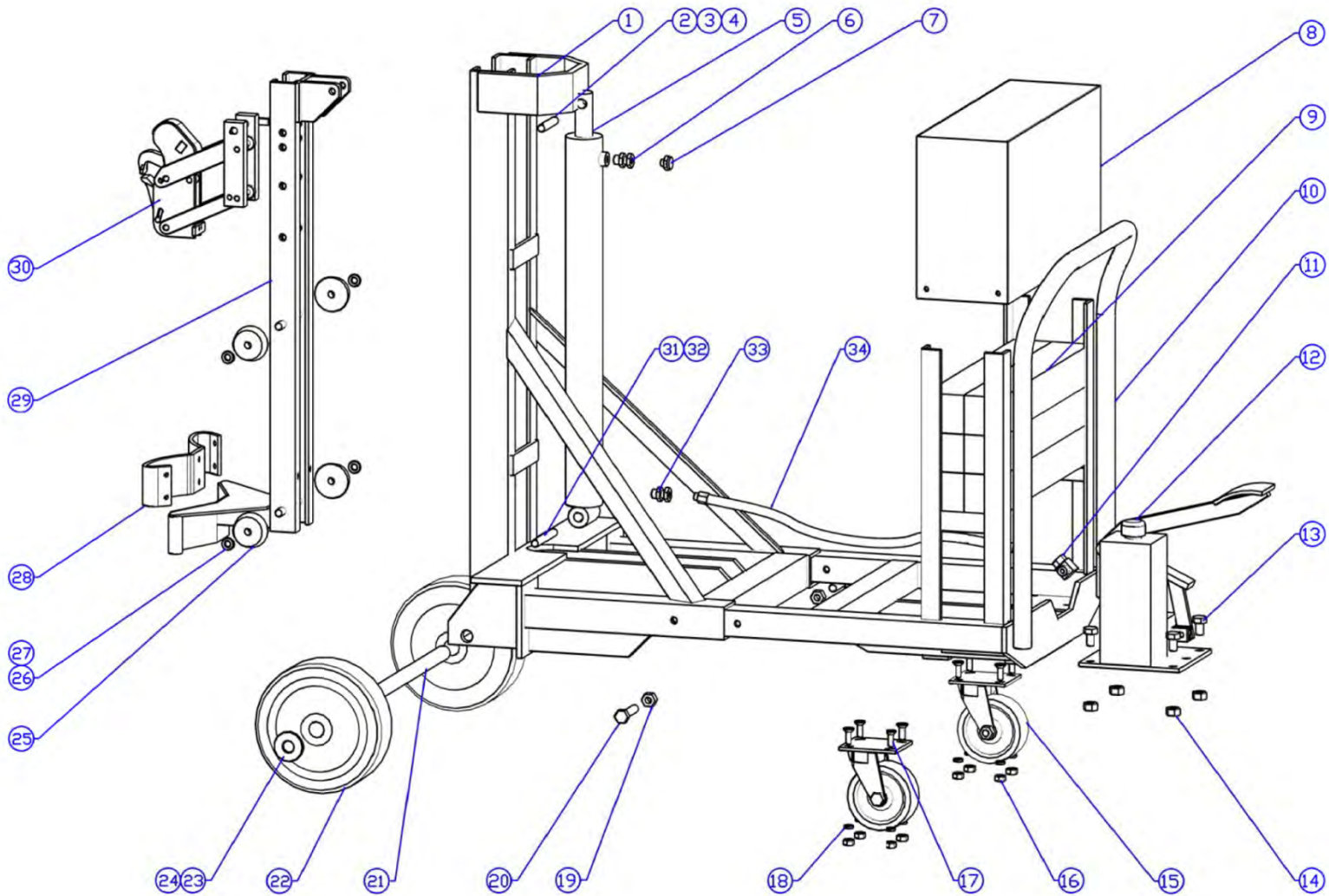



**Liftomatic Material Handling, Inc.**

700 Dartmouth Lane  
Buffalo Grove, IL 60089

Phone 847 325-2930  
Fax 847 325-2959  
Toll Free 800 837-6540

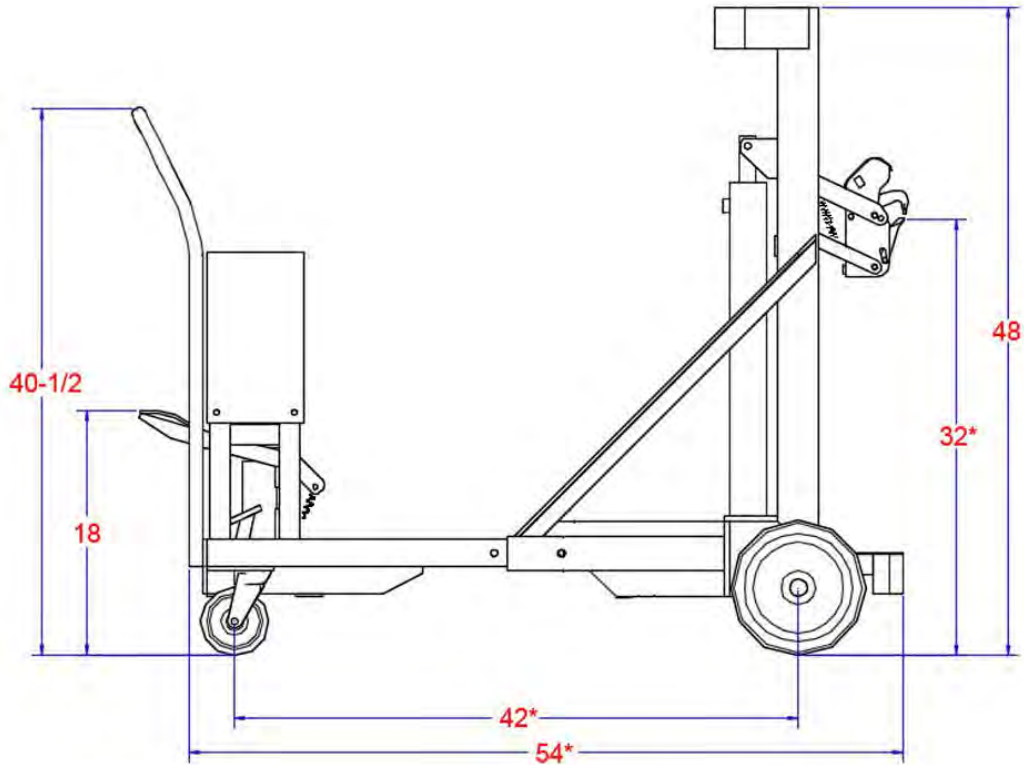

\* Adjustable

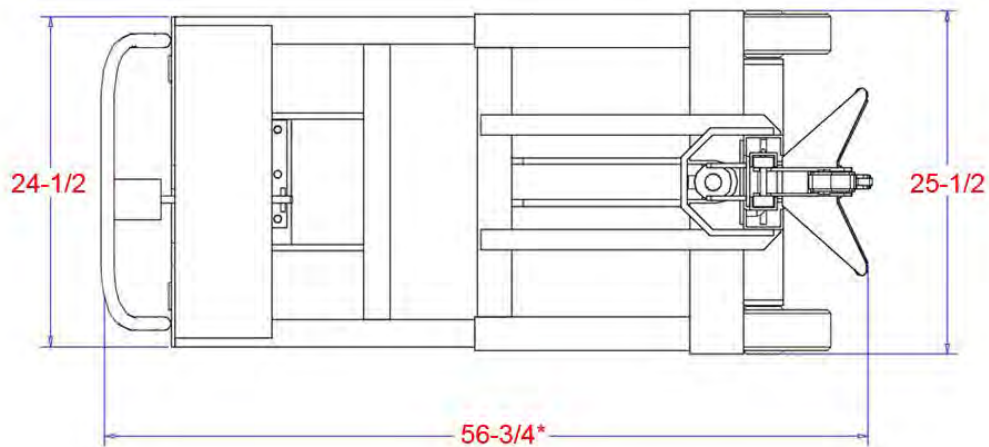

ERGO650-CB-ML